

Universidad Nacional Autónoma de México

Facultad de Estudios Superiores Cuautitlán

Ingeniería Mecánica Eléctrica e

Ingeniería Industrial



DISEÑO ASISTIDO POR COMPUTADORA

EJERCICIOS

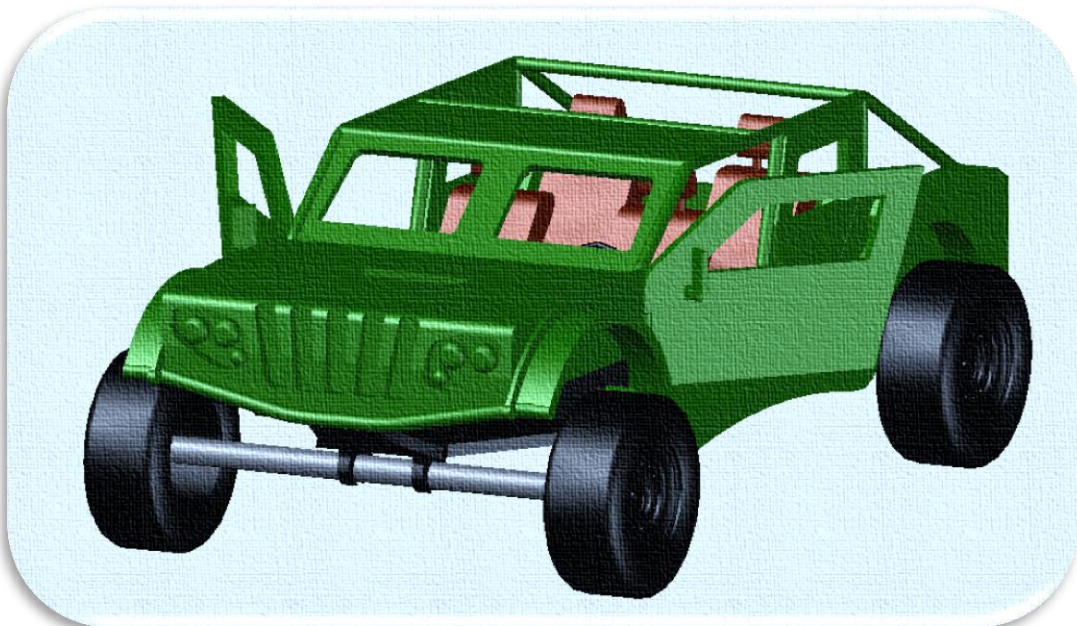

Mtro. FELIPE DÍAZ DEL CASTILLO RODRIGUEZ

CUAUTITLÁN IZCALLI, EDO. DE MÉXICO.

2019-1

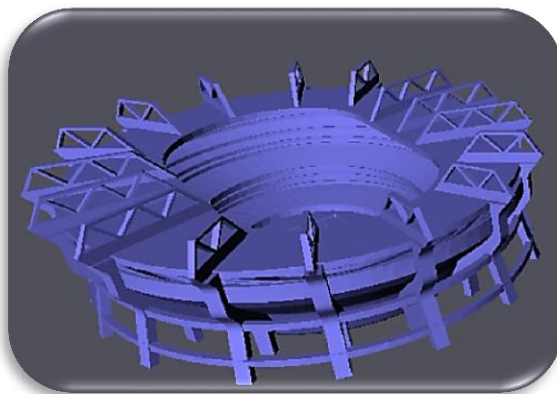
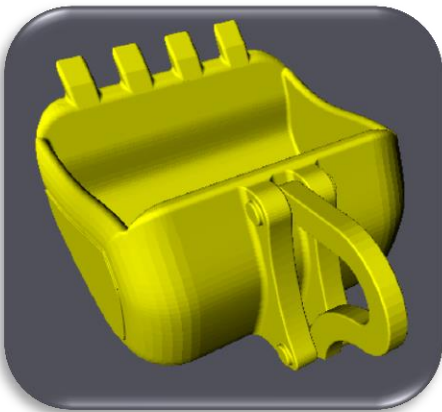
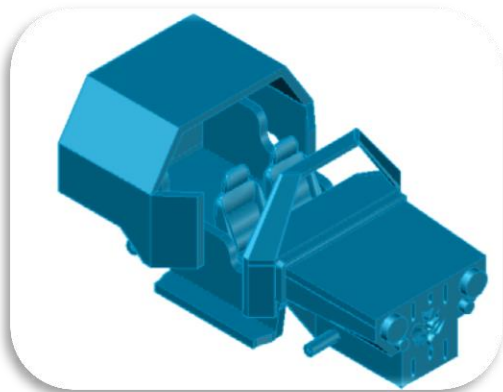
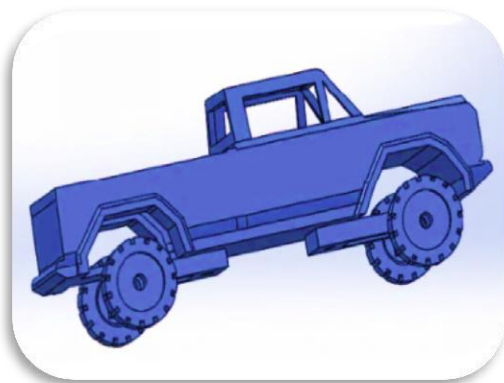

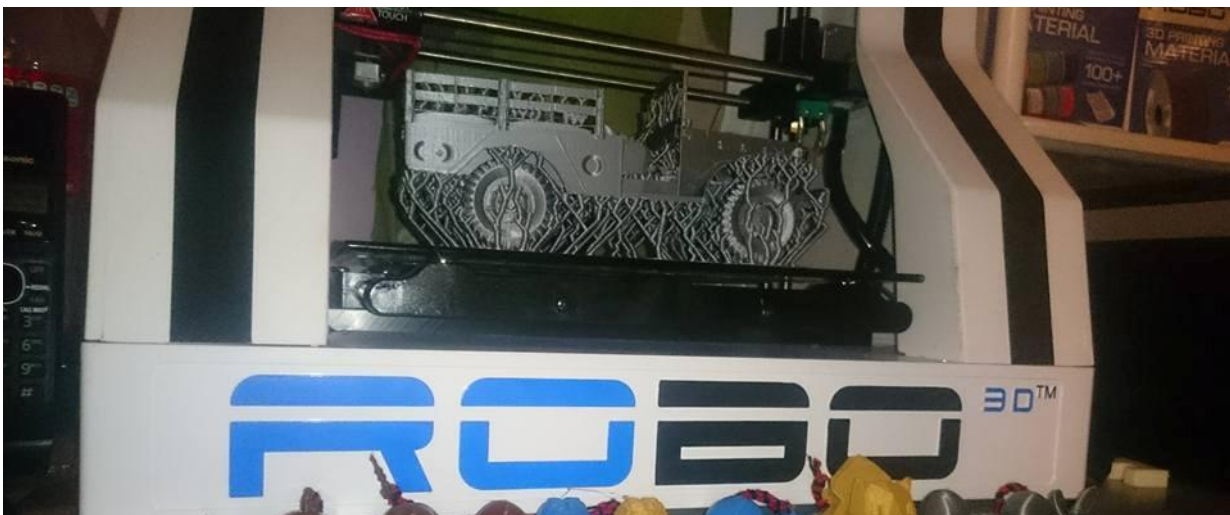
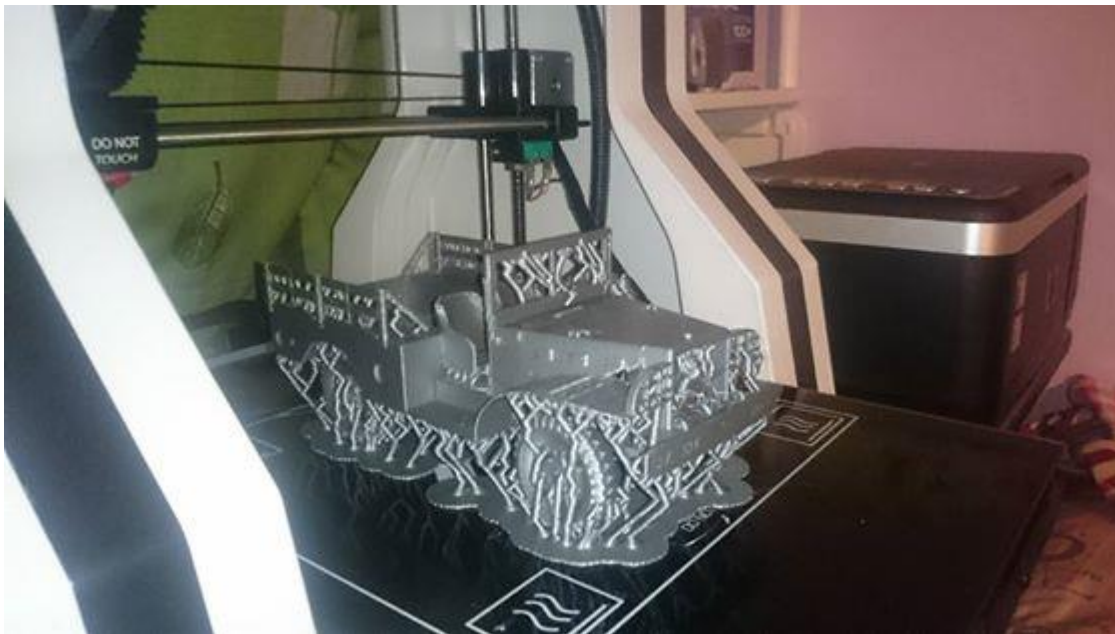
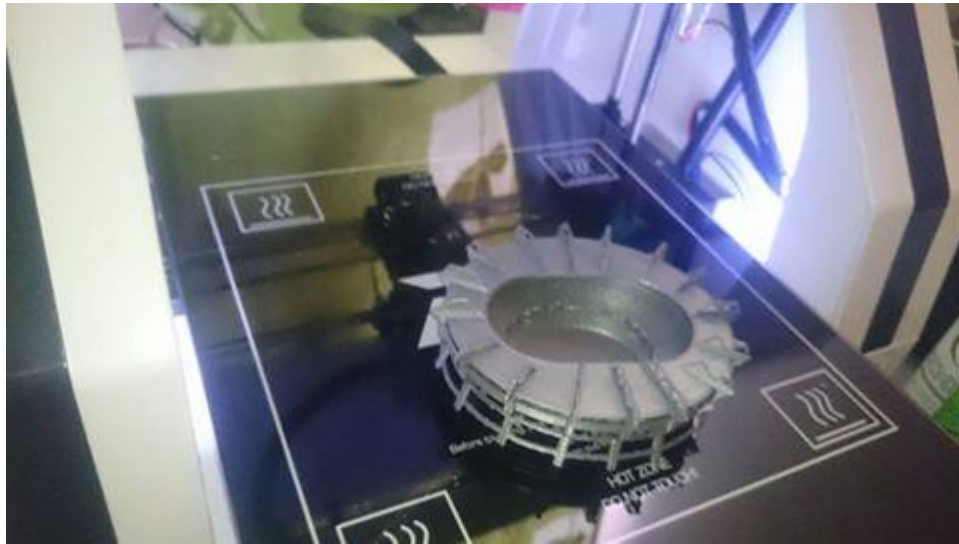

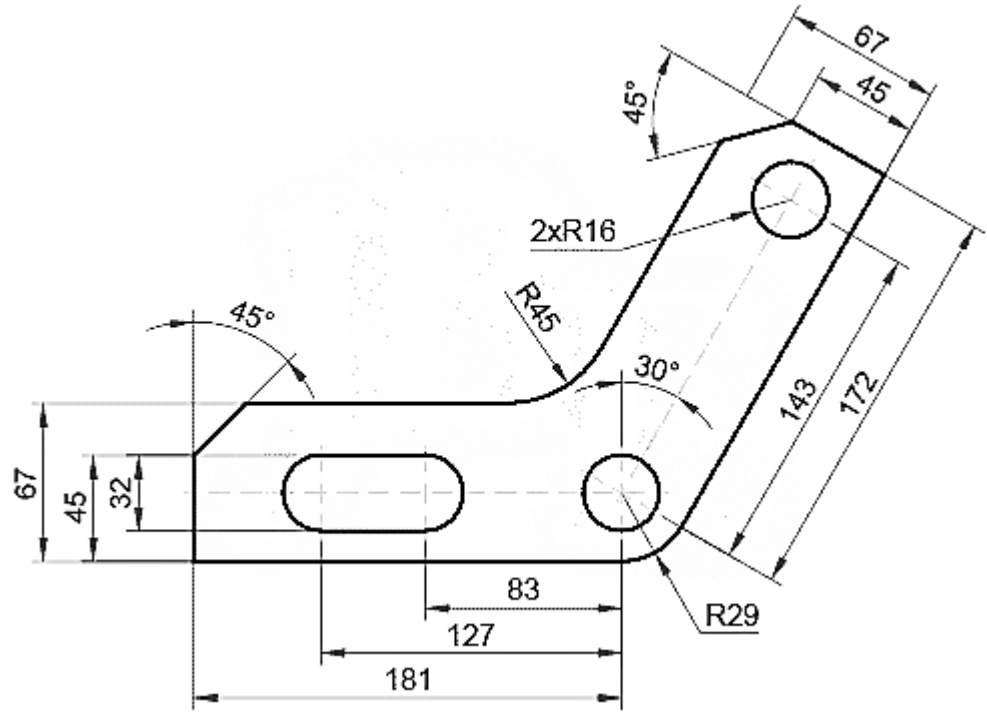

Ejercicio 1.

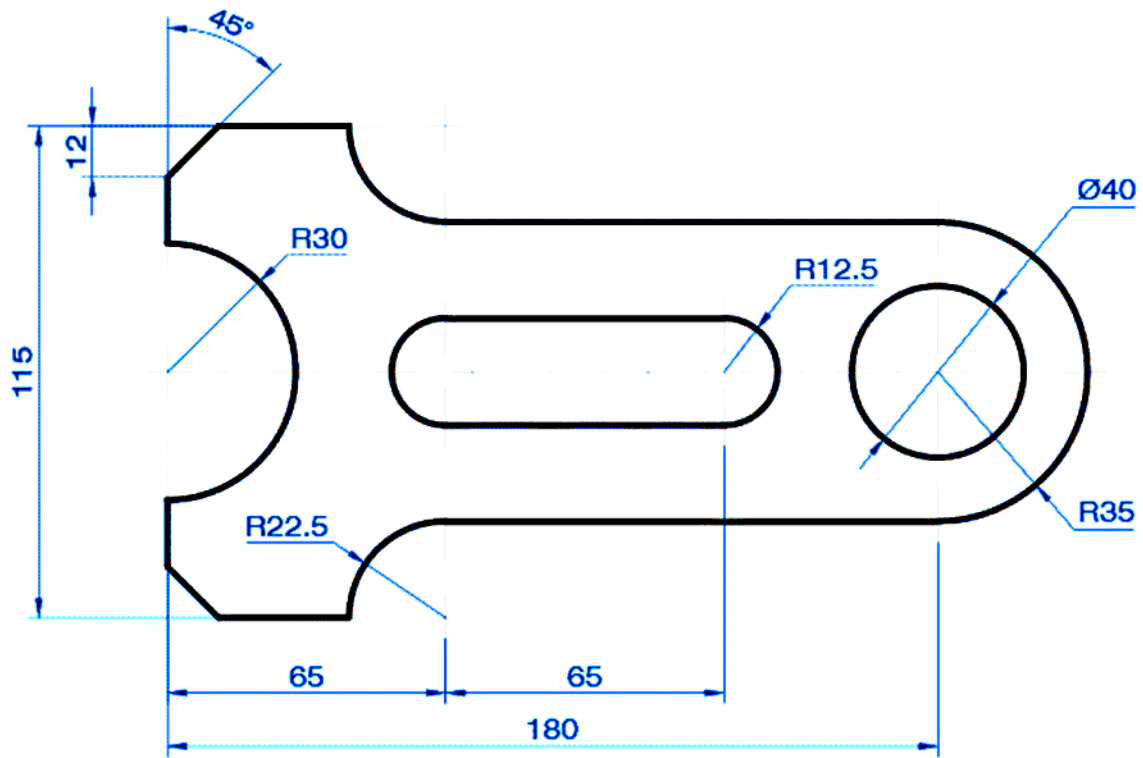

Ejercicio 2.

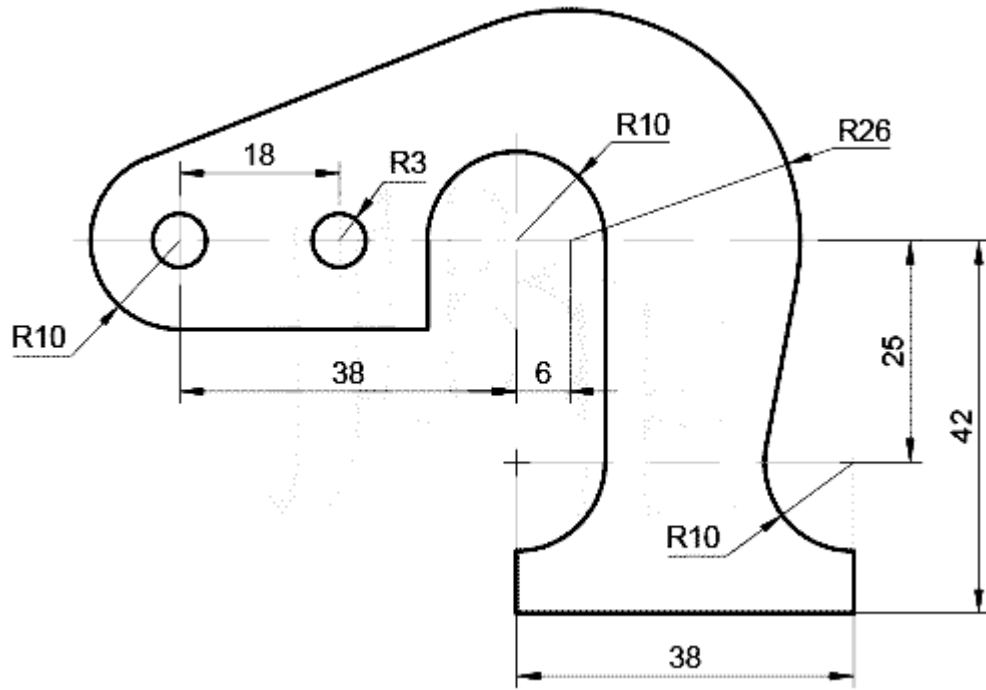

Ejercicio 3.

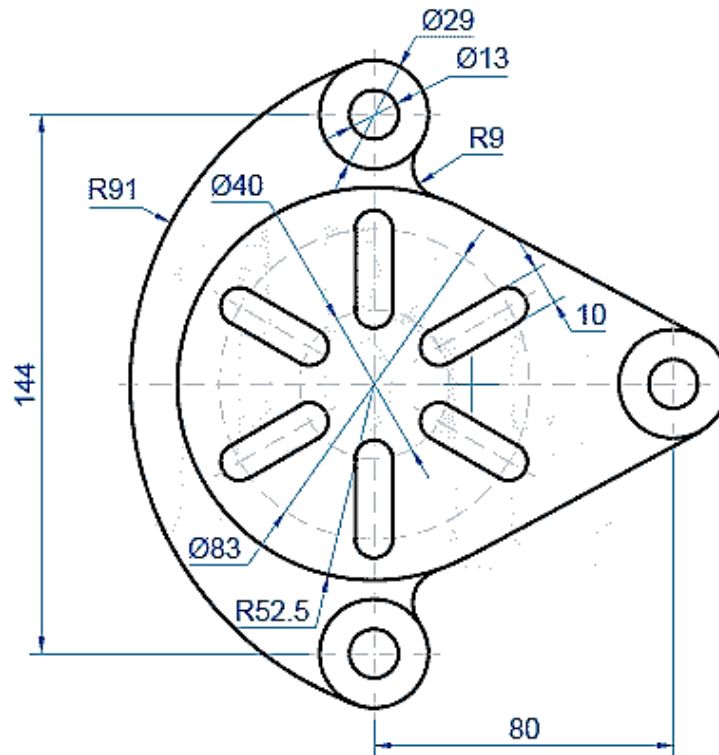

Ejercicio 4.

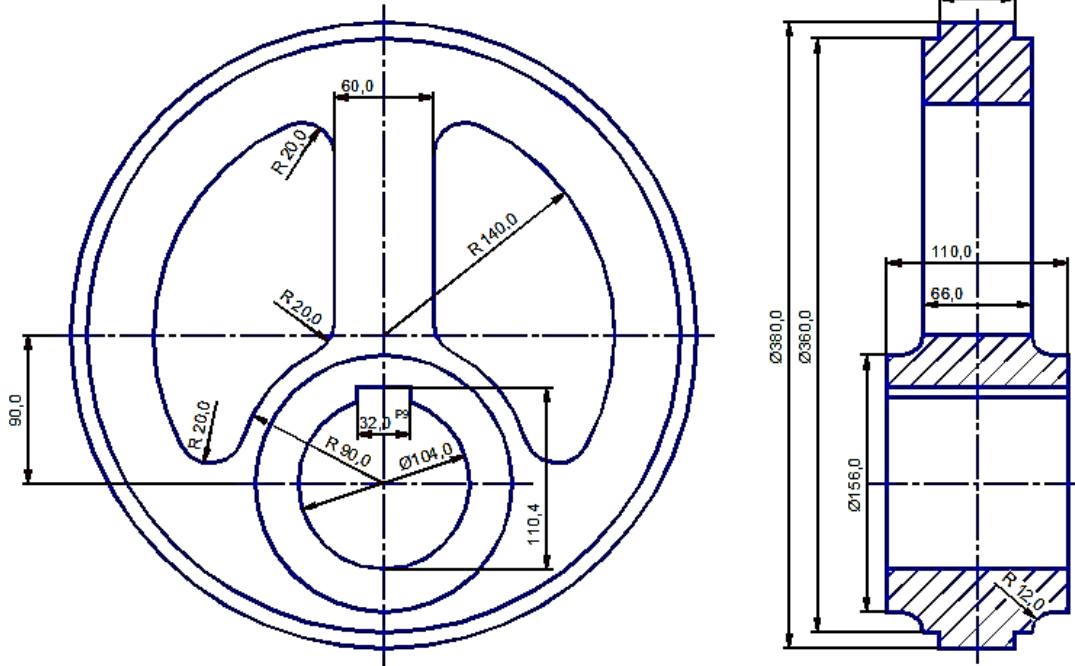

Ejercicio 5.

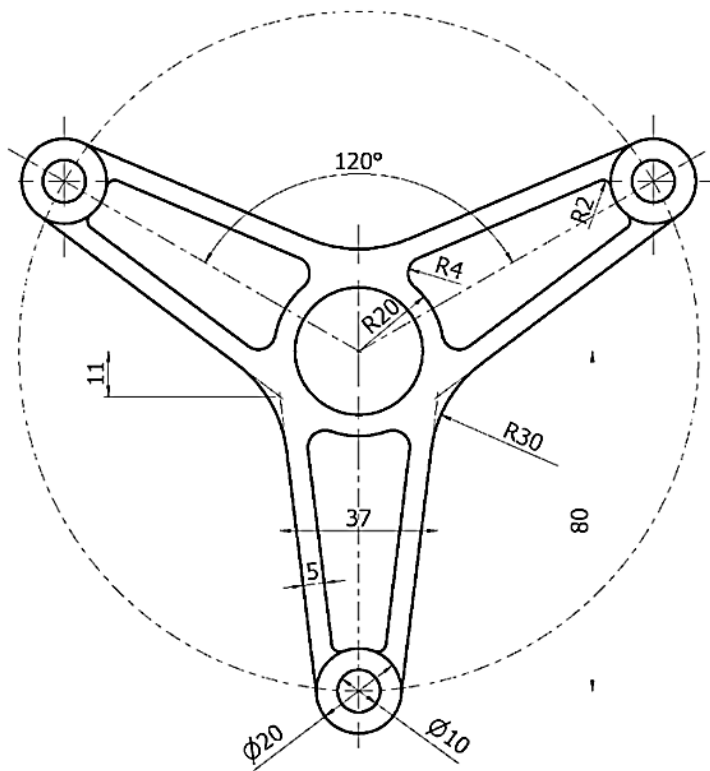

Ejercicio 6.

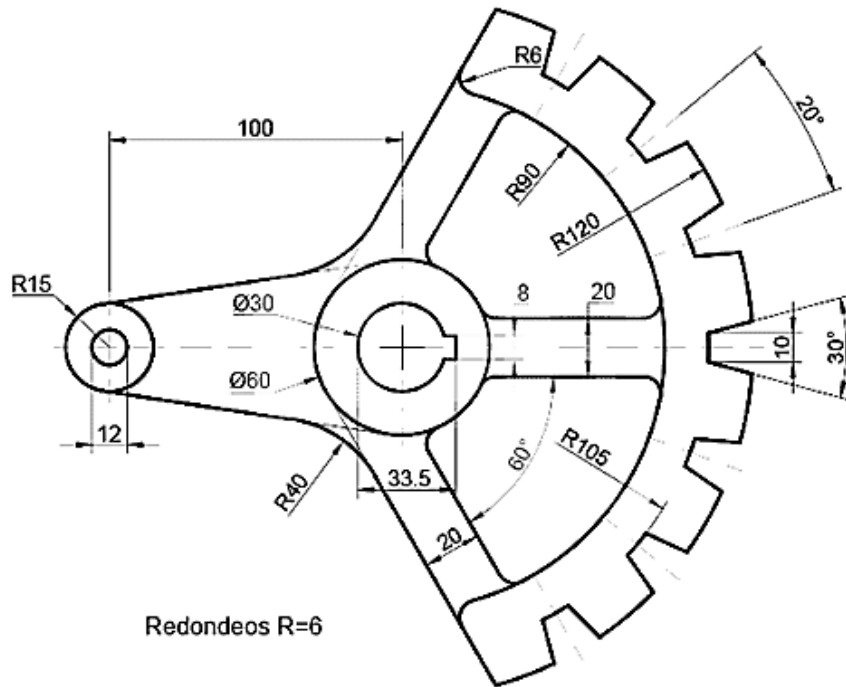

Ejercicio 7

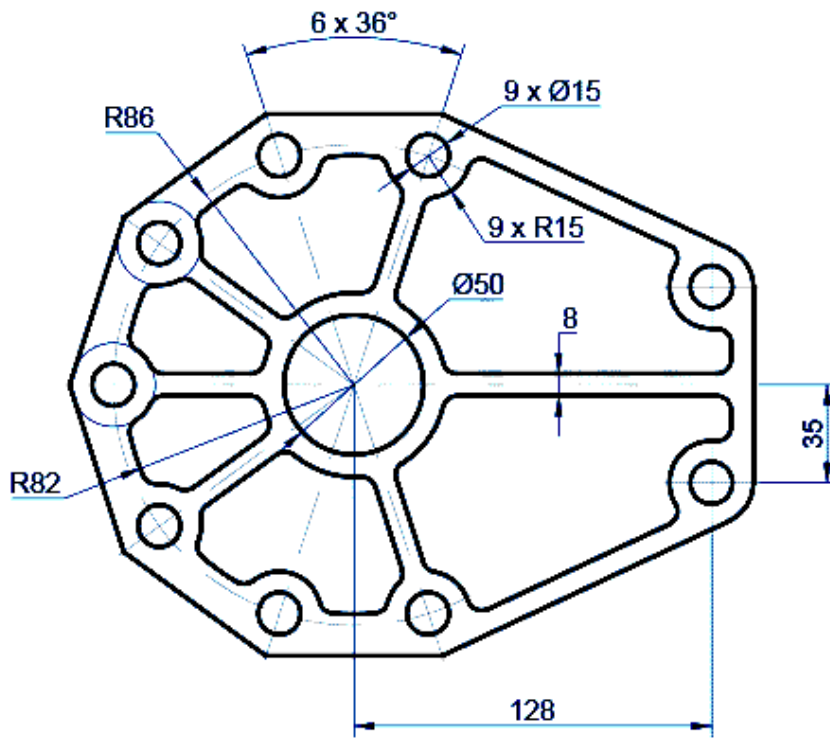

EJERCICIO 8

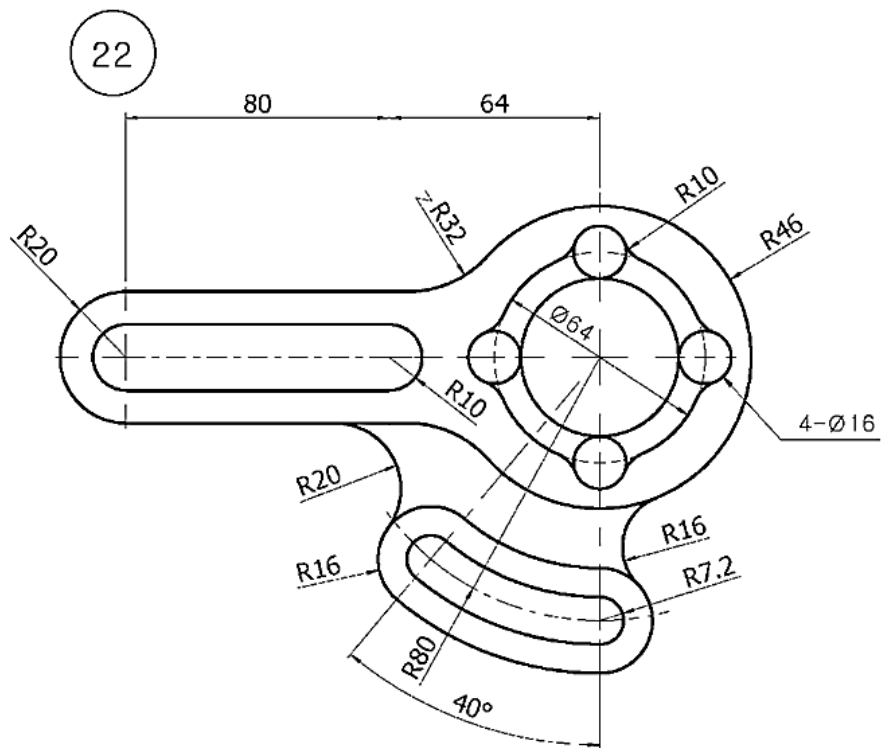

Ejercicio 9.

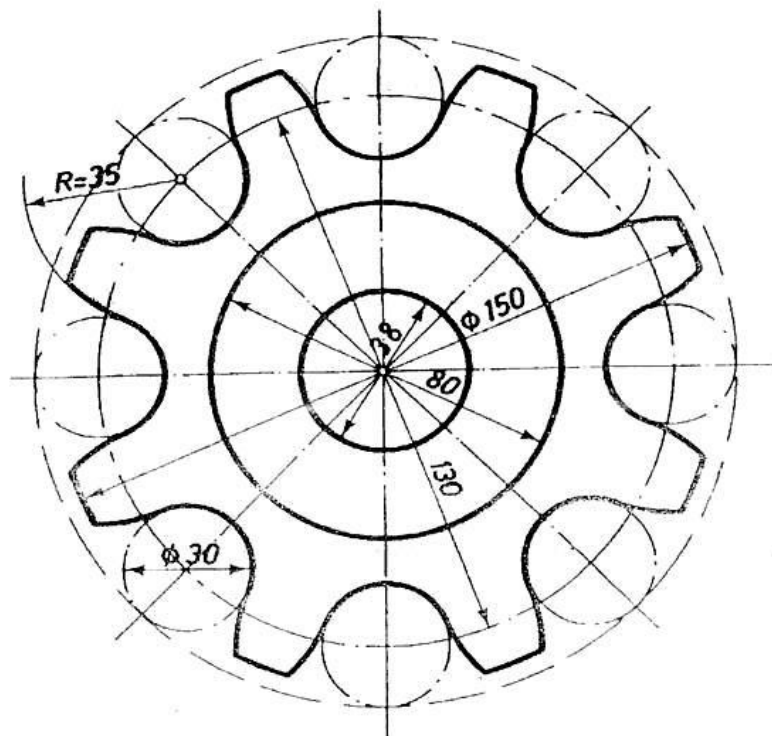

Ejercicio 10

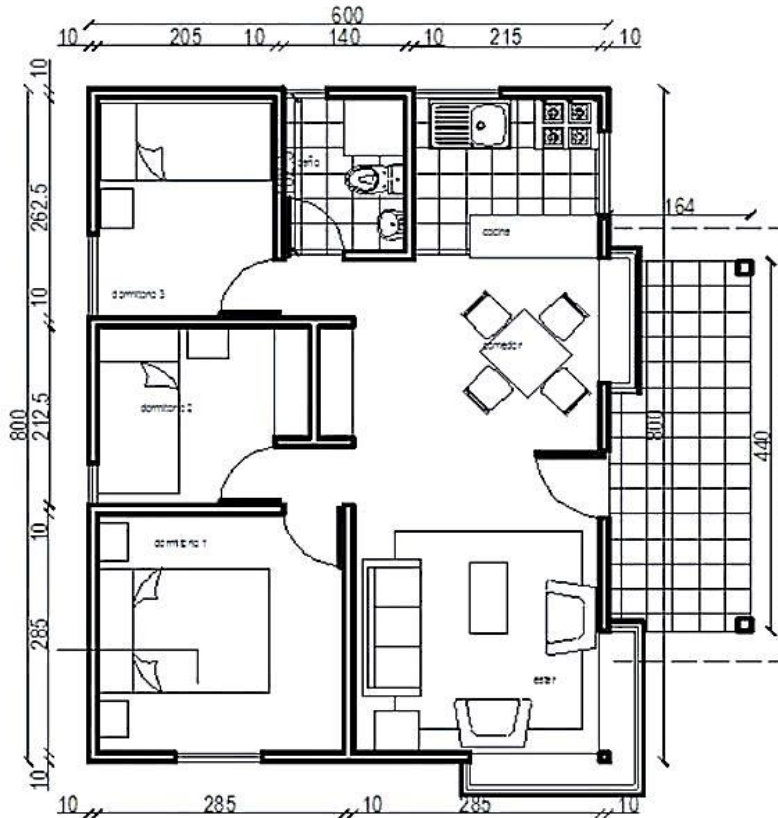

Ejercicio 11

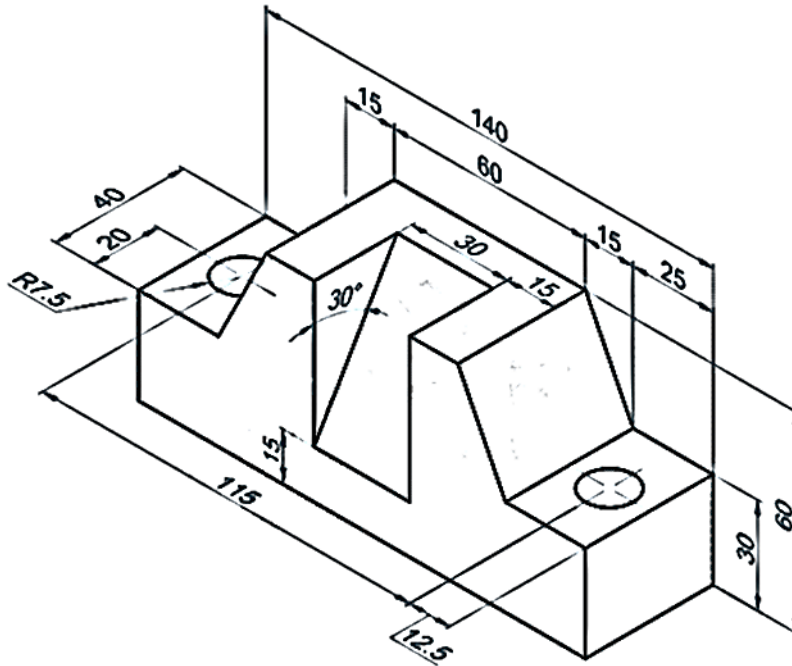

Ejercicio 12

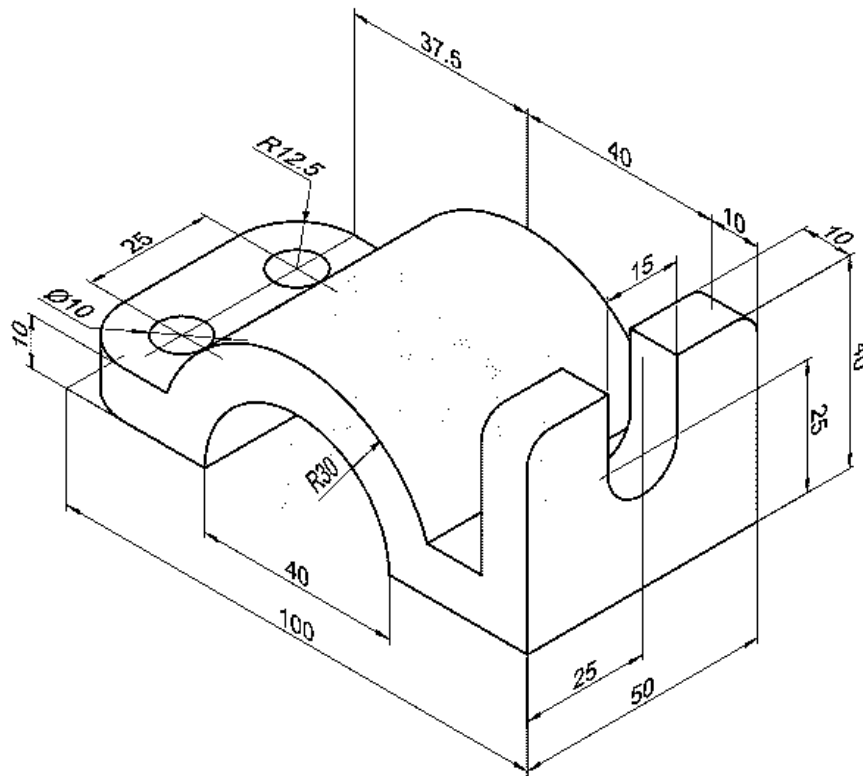

Ejercicio 13

GUÍA EN COLA DE MILANO

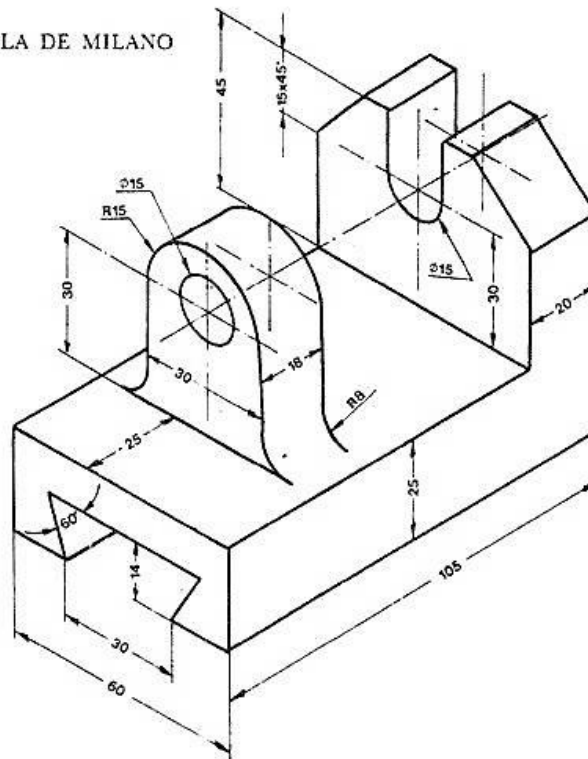

Ejercicio 14.

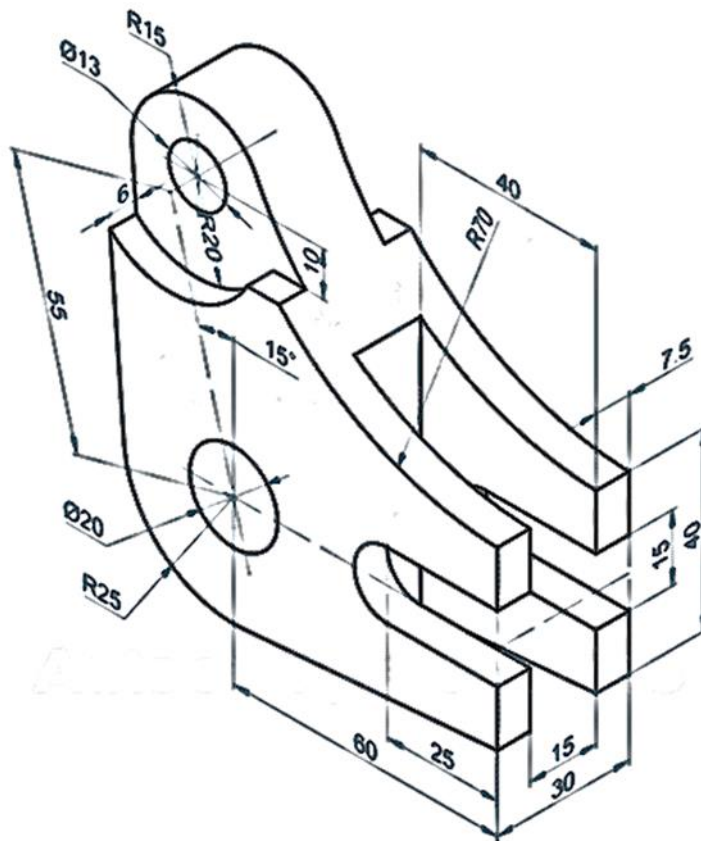

Ejercicio 15.

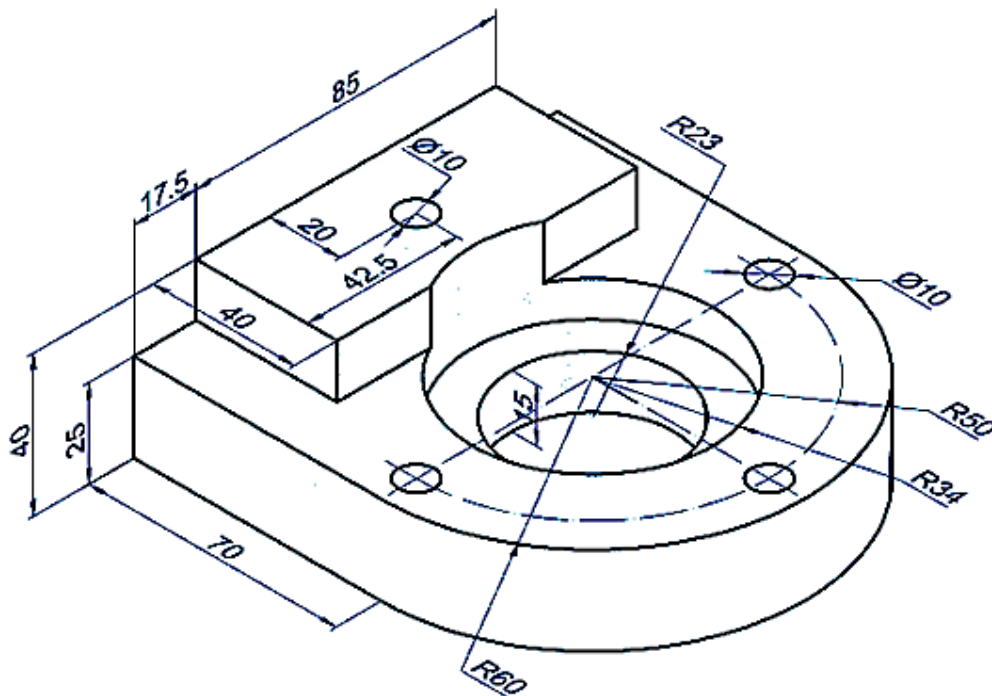

Ejercicio 16.

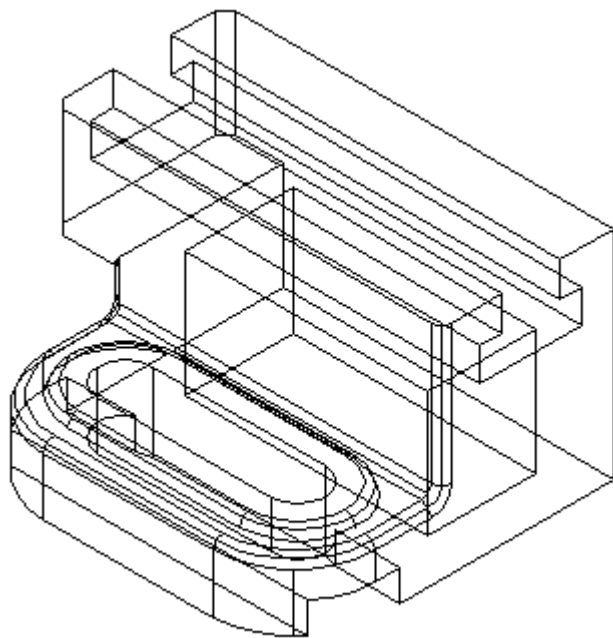
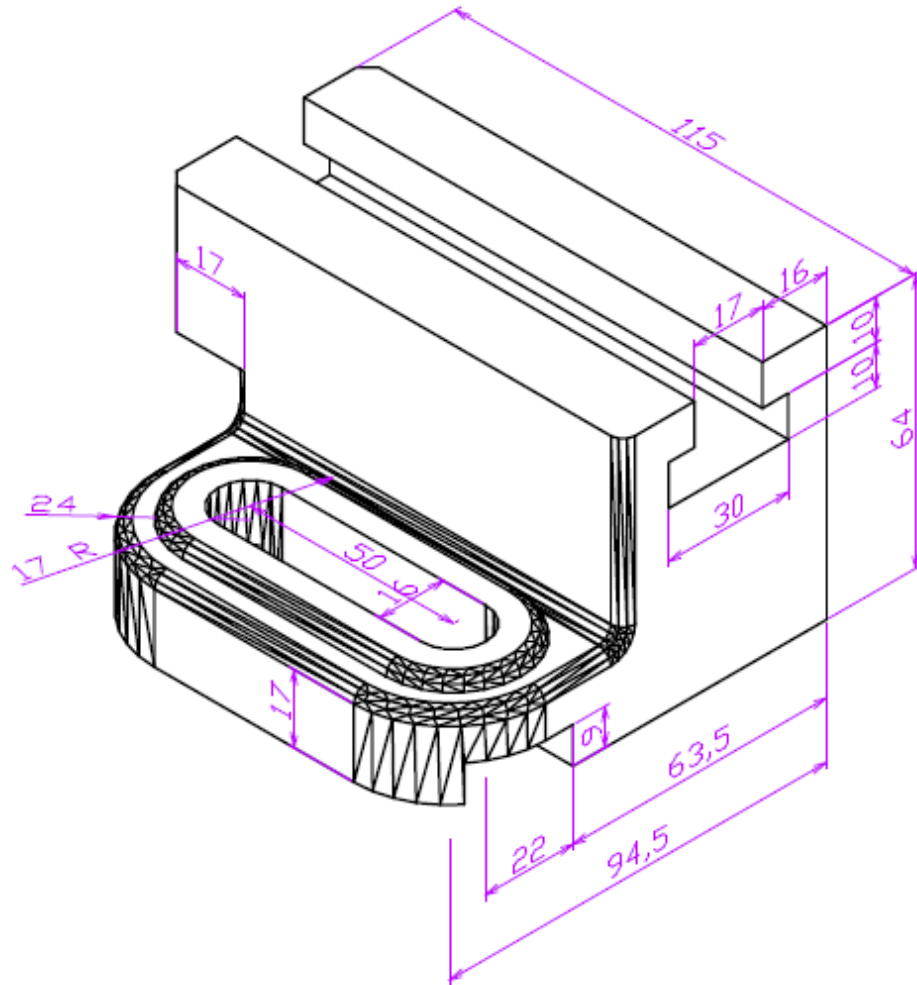

Ejercicio 17.

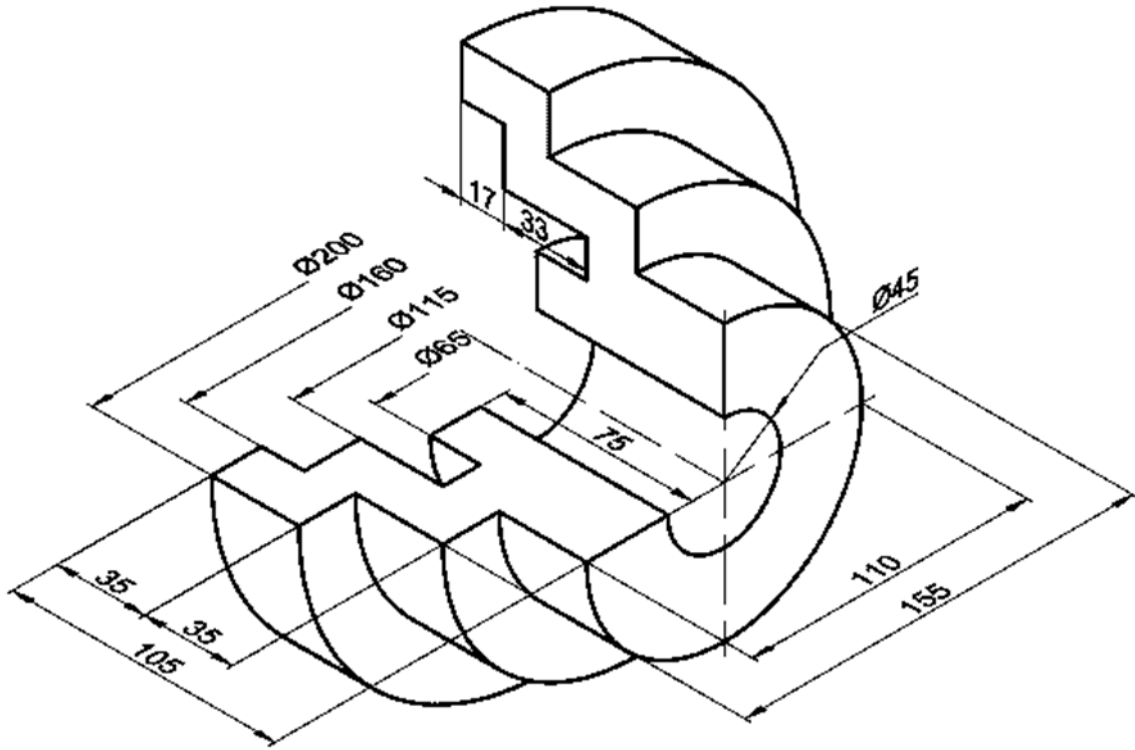

Ejercicio 18

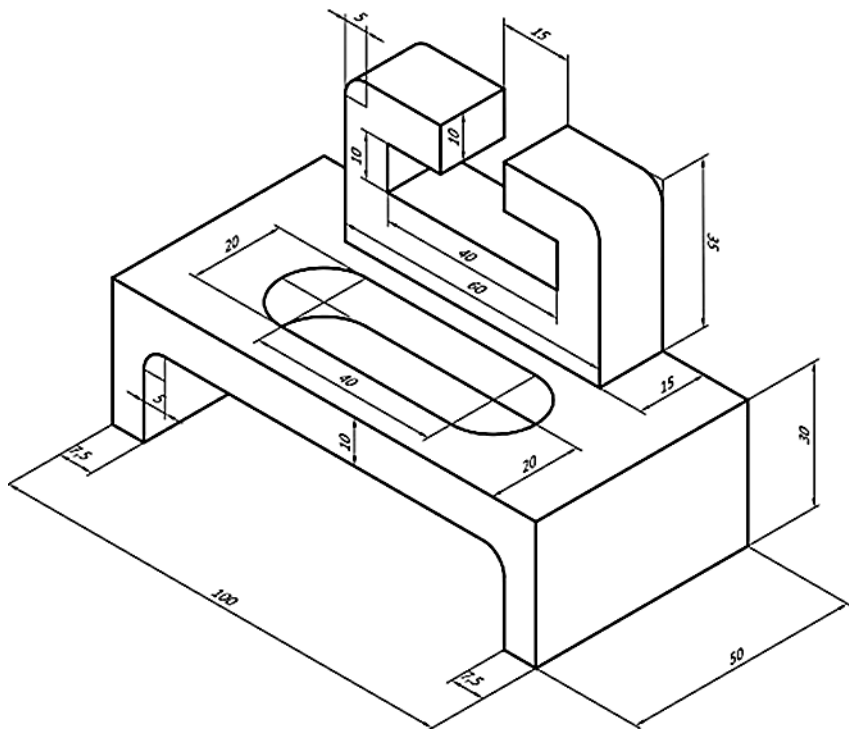

Ejercicio 19

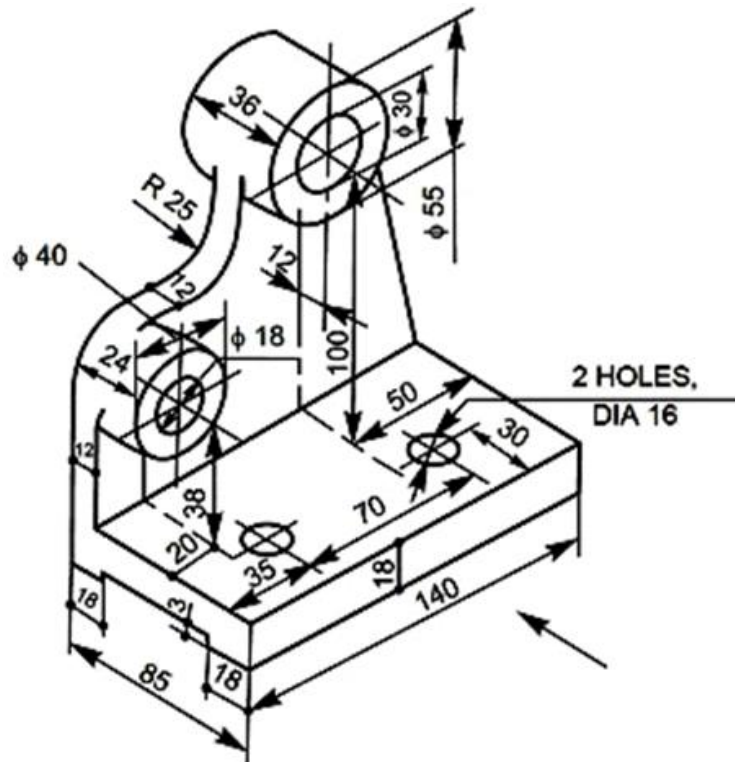

Ejercicio 20

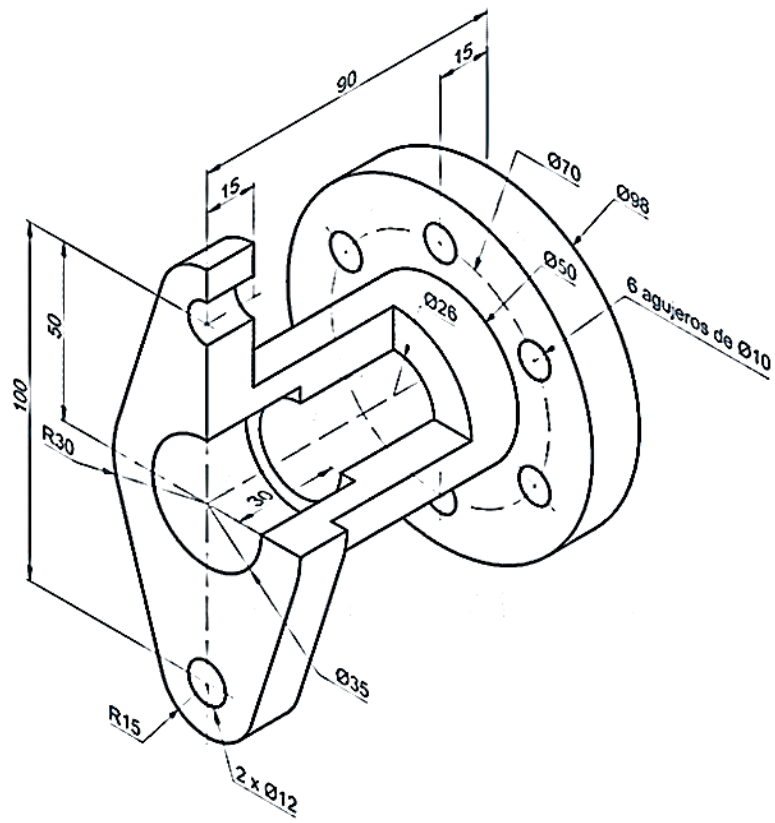

Ejercicio 21

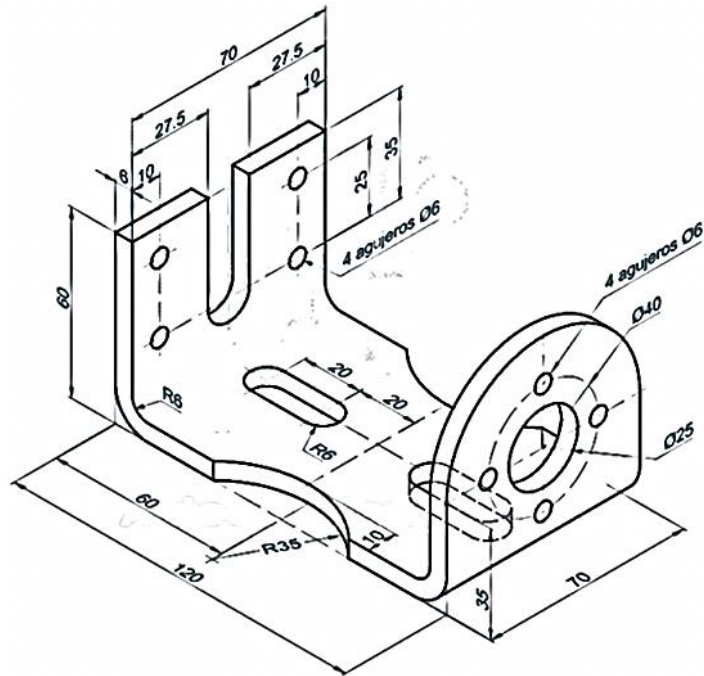

EJERCICIO 22

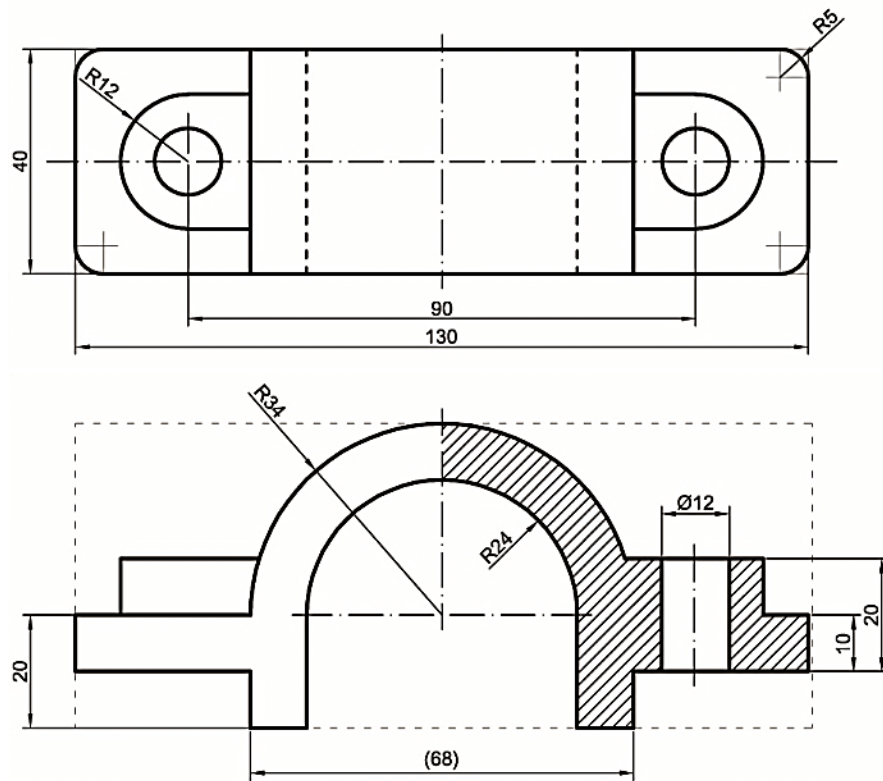

Ejercicio 23

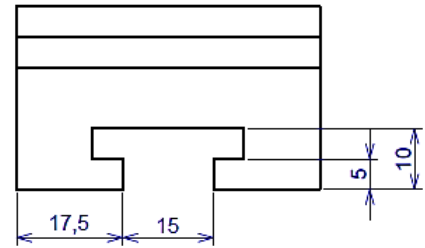
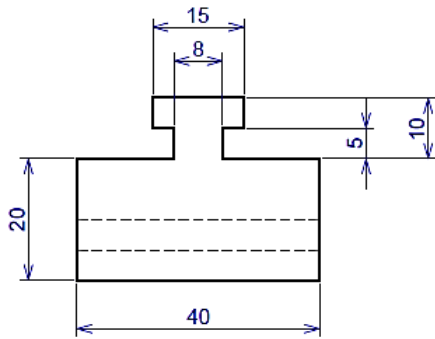
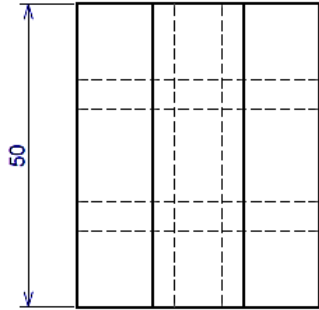

Ejercicio 24

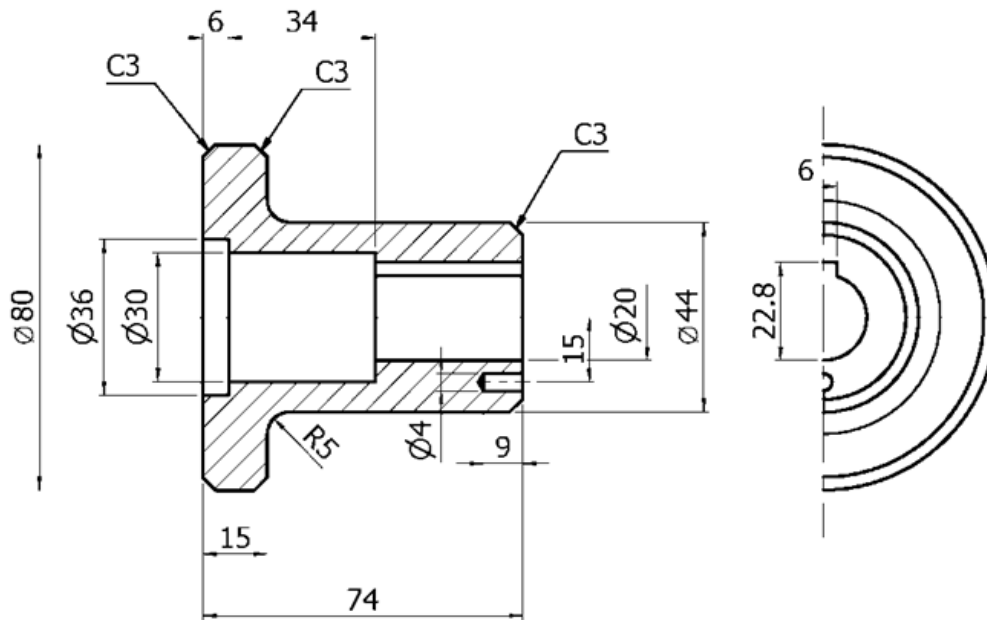

Ejercicio 25

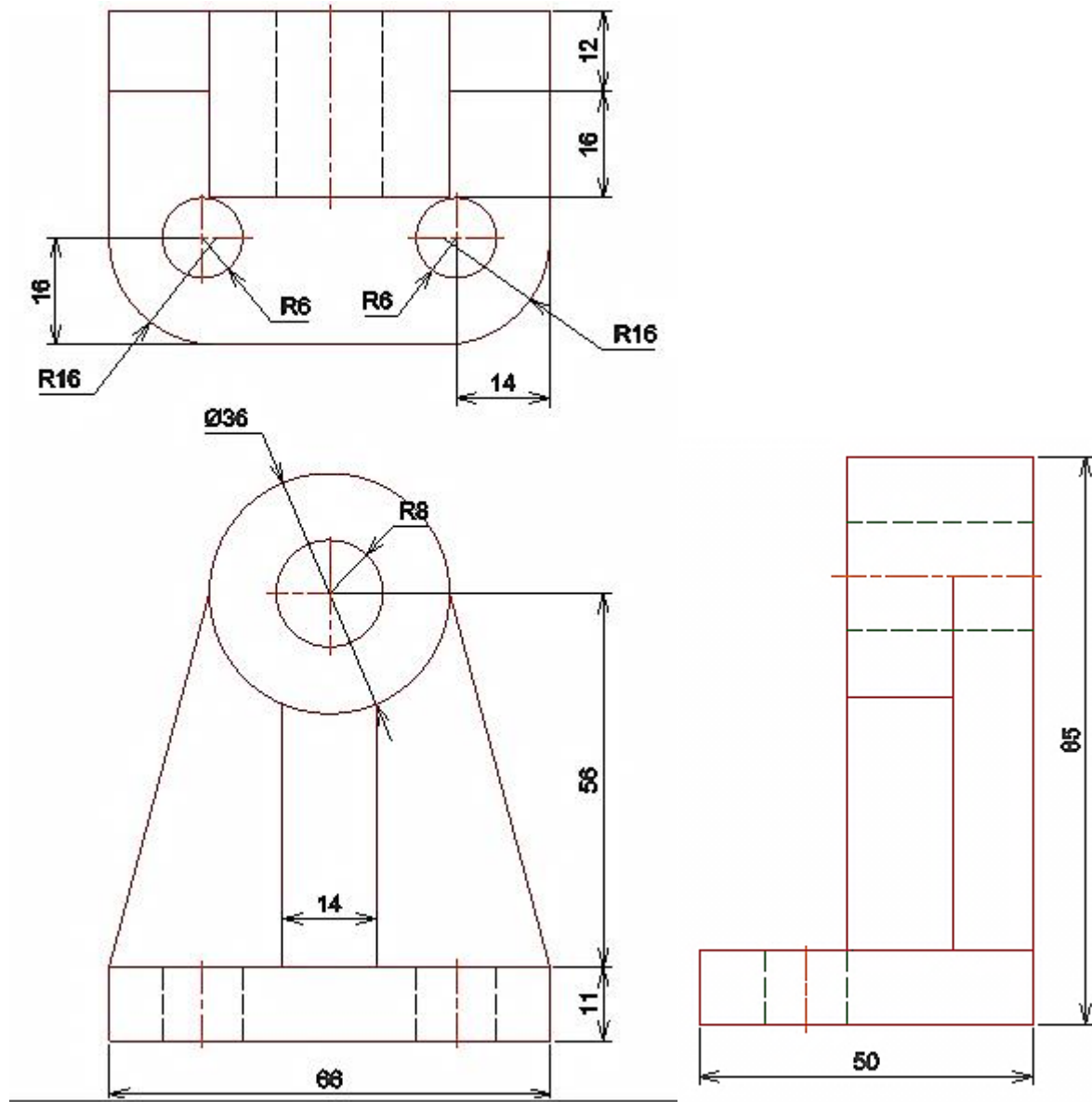

Ejercicio 26

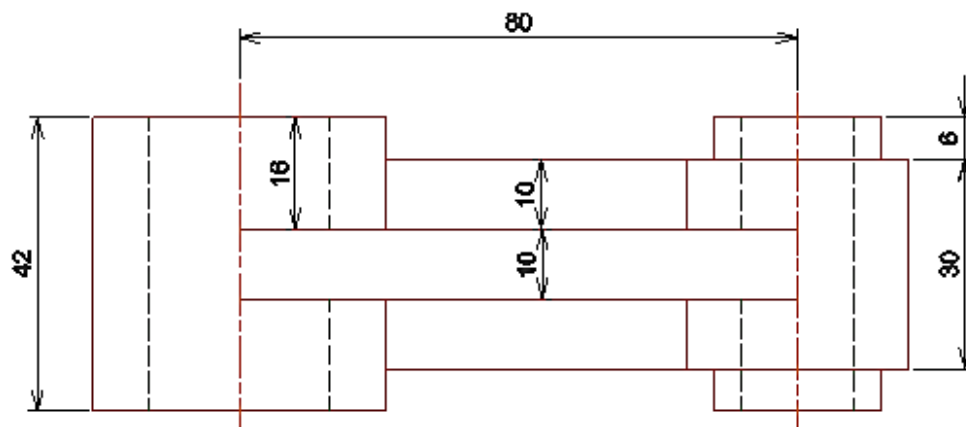
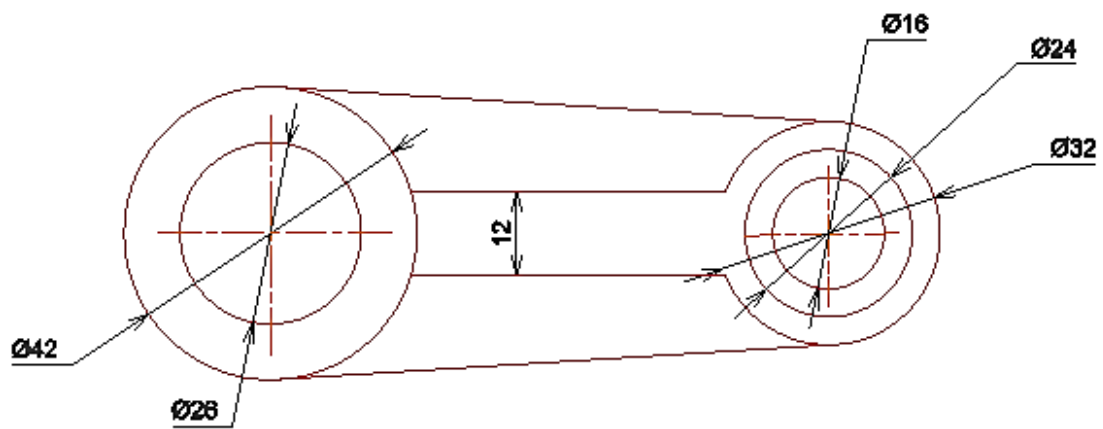

Ejercicio 27.

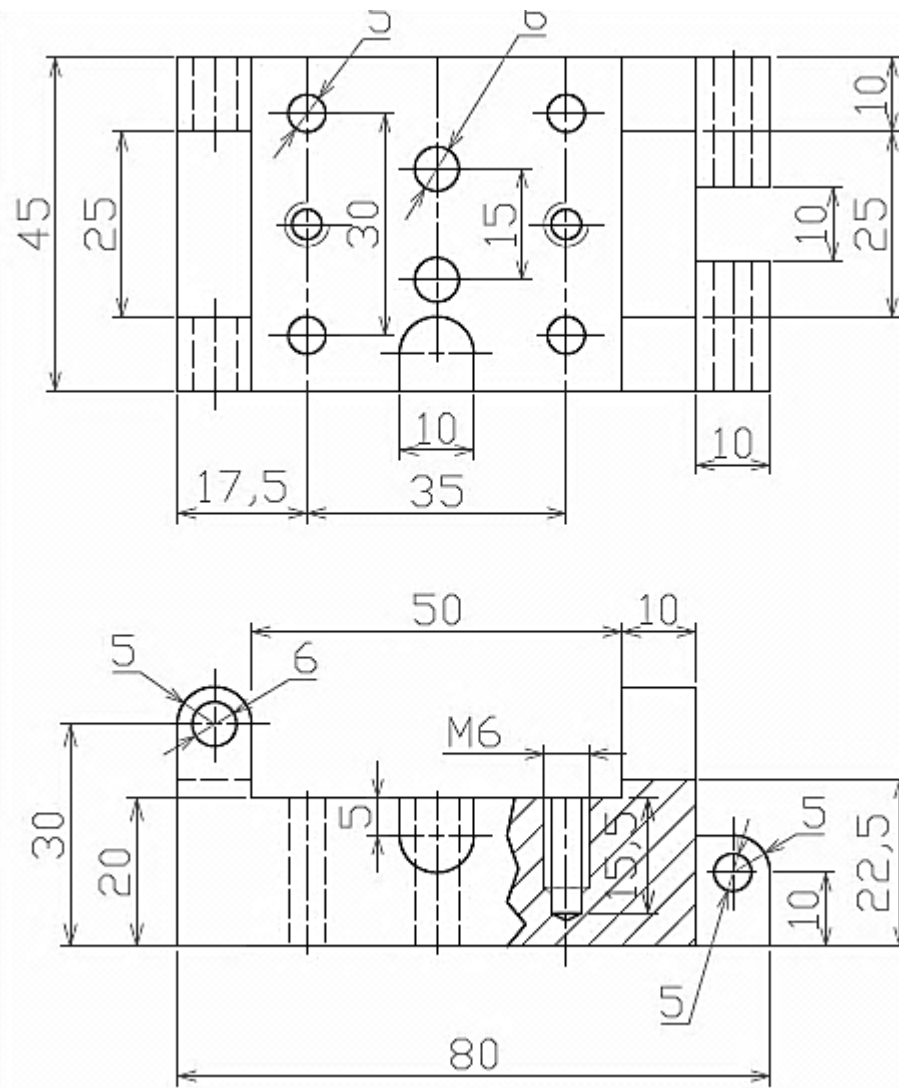

Ejercicio 28

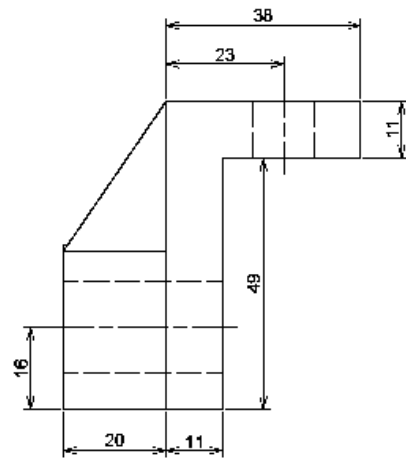
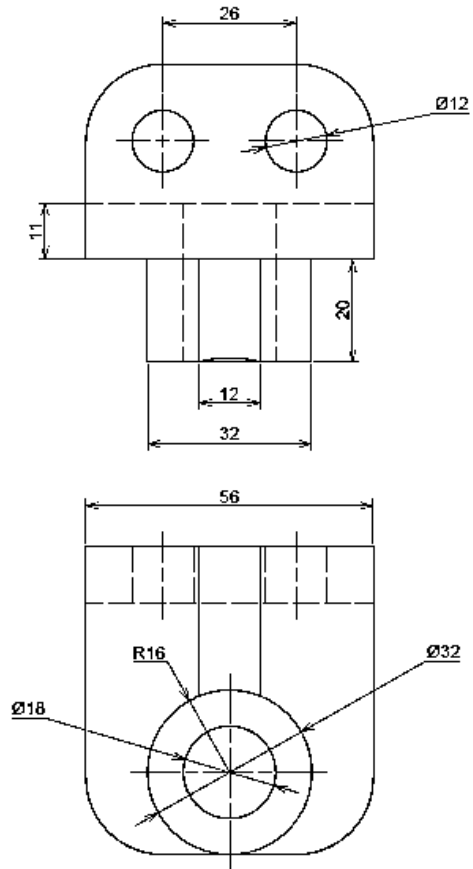

EJERCICIO 29.

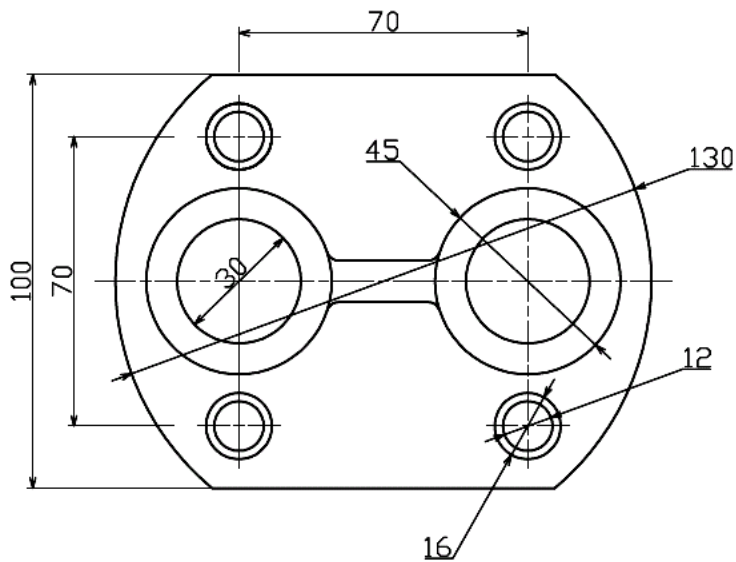

EJERCICIO 30

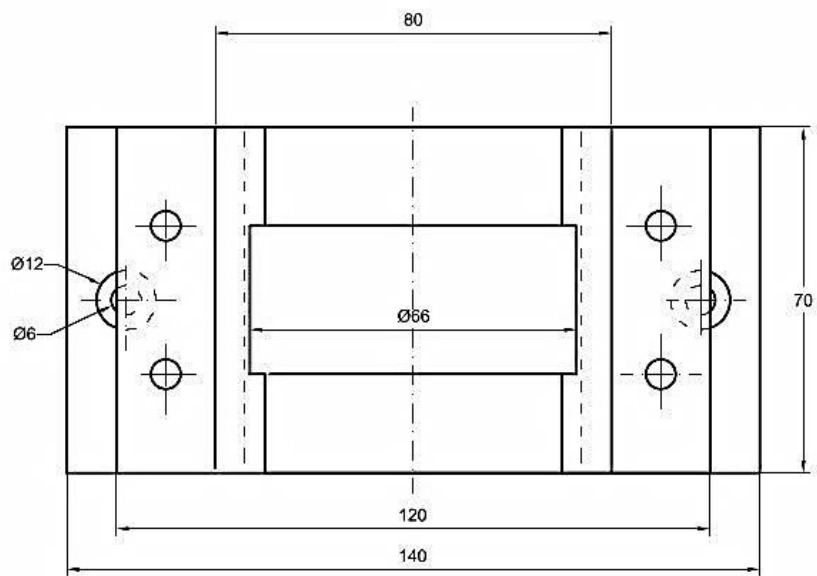
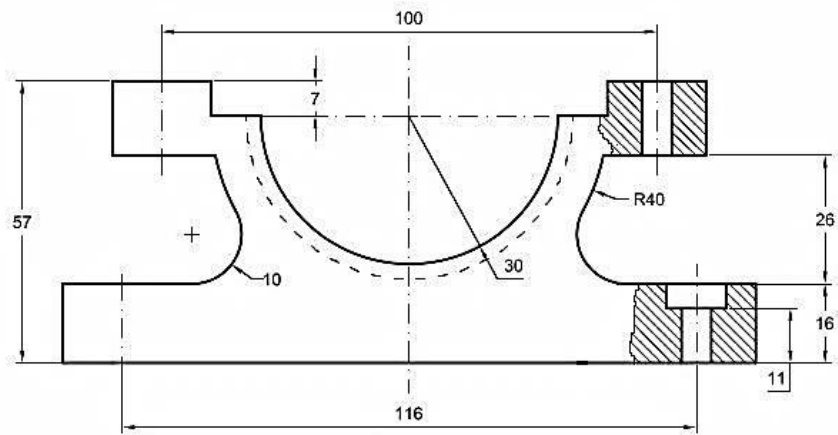

Ejercicio 31

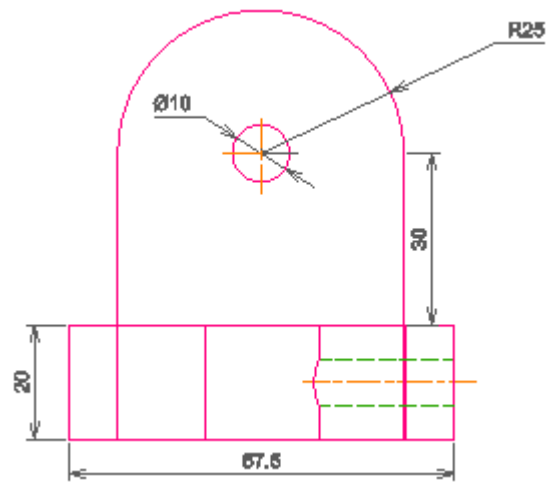
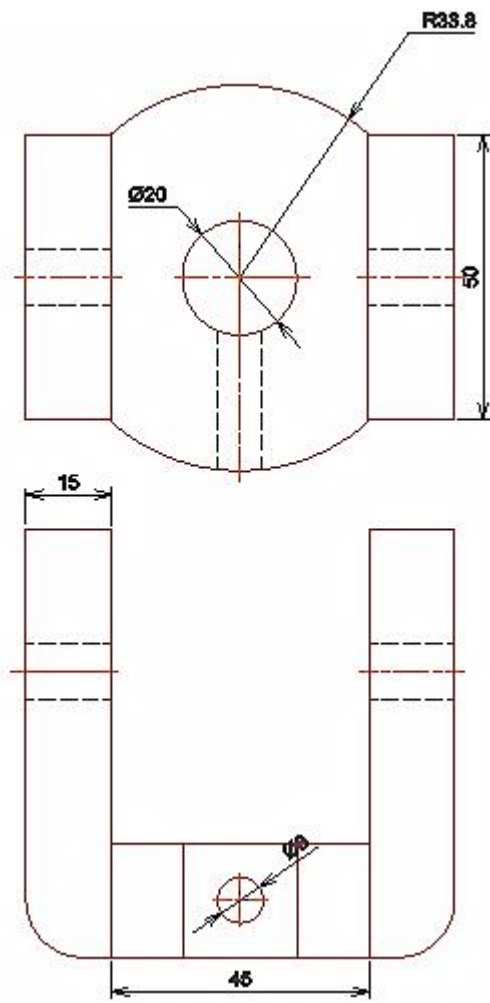

Ejercicio 32

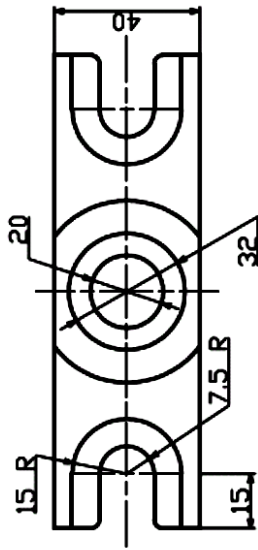

Nota: Radios no acotados = 2.5 mm

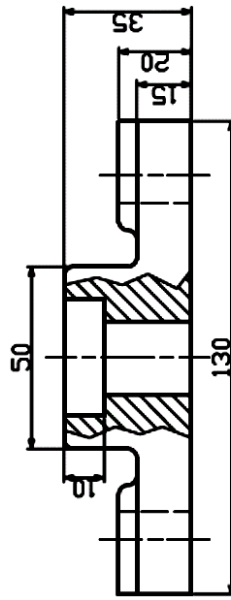

ESQ. 1:1	FES-C	CUNARD	8/09/07	DIB.F.D.C.R
Acotado	BASE SIMPLE		REV1	No. 7
	MATHIERRO FUNDIDO			

EJERCICIO 33.

PROYECTO FINAL

ESC:1:35



1. Toyota Land Cruiser FJ40



2. Porsche 597



3. ASCOD ('Austrian-Spanish Cooperation Development', por sus siglas en inglés)



4. Camión M34



5. IVECO Massit



6. Suzuki Jimny



7. Pick Up Powell (Australia)



8. Pick Up Ramirez Rural (México)



9. Camioneta Dodge 3 tons. 1970



10. Mercedes Benz Zetros